



PRIMARY 3 PRACTICE PAPER (2024)

Name : _____ ()

Date: _____

Class : Primary 3 ()

SCIENCE BOOKLET A

INSTRUCTIONS TO CANDIDATES

1. Write your name, class and register number.
2. Do not turn over this page until you are told to do so.
3. Follow all instructions carefully.
4. Answer all questions.
5. Shade your answers on the Optical Answer Sheet (OAS) provided.

Booklet A (17 x 2 marks)

For each question from 1 to 17, four options are given. One of them is the correct answer. Make your choice (1, 2, 3 or 4) and shade your answer on the Optical Answer Sheet.

(34 marks)

1. The pictures below show some characteristics of living things. Which of the following shows that living things can respond to changes?

(1) A hen lays eggs in a nest.

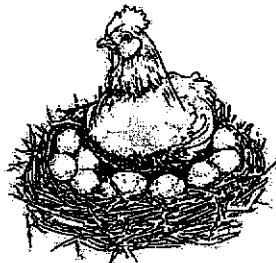

(2) A baby becomes a boy over five years.

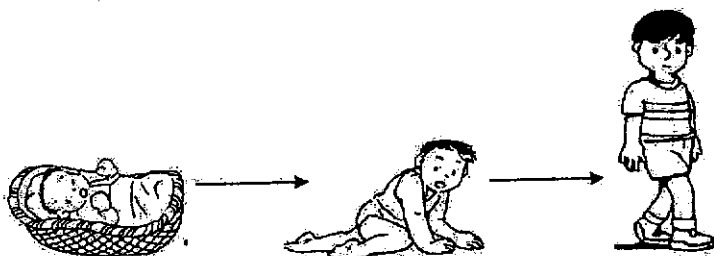

(3) A bird feeds on the nectar of a flower.

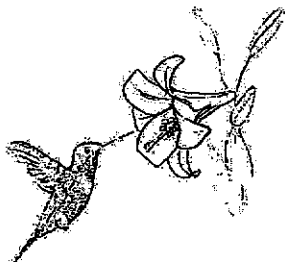

(4) A tortoise hides in its shell when touched.

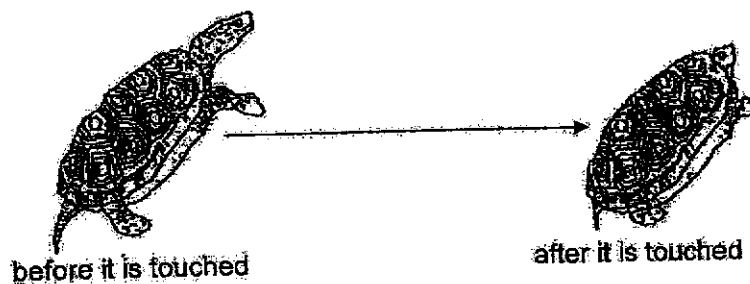

2. Ken conducted an experiment using four set-ups as shown below.

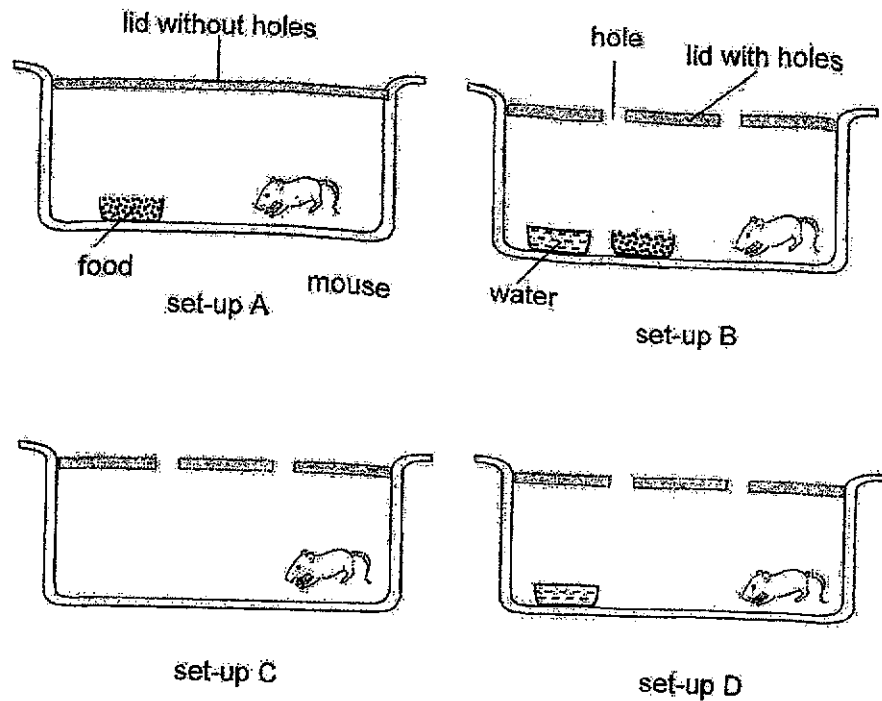

Which two set-ups should he use to find out if living things need food to survive?

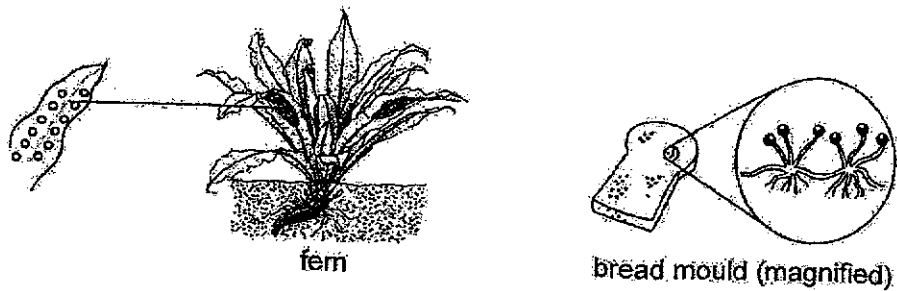

- (1) A and D
 - (2) B and C
 - (3) A and C
 - (4) B and D
3. Study the pictures below.



Which statement about the bread mould and the fern is correct?

- (1) Both produce flowers.
- (2) Both make their own food.
- (3) Both need sunlight to grow.
- (4) Both reproduce from spores.

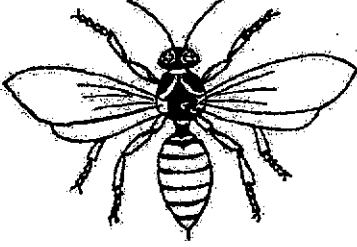
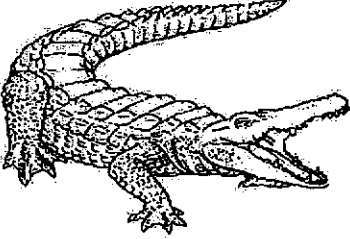
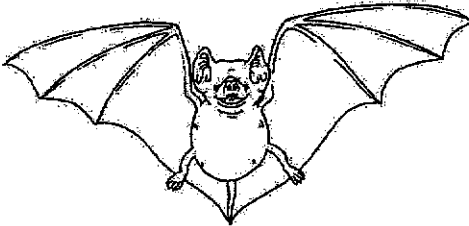
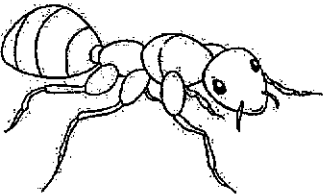
4. Jane grouped some animals into Group E and Group F as shown below.

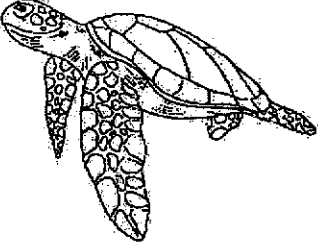
Group E	Group F
	
	
	

Which of the following characteristics of animals did Jane use to classify the animals?

- (1) number of legs
- (2) presence of tail
- (3) presence of wings
- (4) number of body parts

5. The table below shows the characteristics of four different living things, A, B, C and D. A tick (✓) means the living thing has the characteristic.

Characteristic	A	B	C	D
It makes its own food.		✓		✓
It reproduces from seeds.				✓
It responds to changes around it.	✓	✓	✓	✓
It can only be seen using a microscope.	✓			

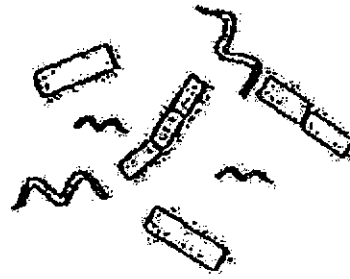

bacteria

From the table above, which of the living things, A, B, C or D, could be bacteria?

- (1) A
- (2) B
- (3) C
- (4) D

6. Study the classification chart below.

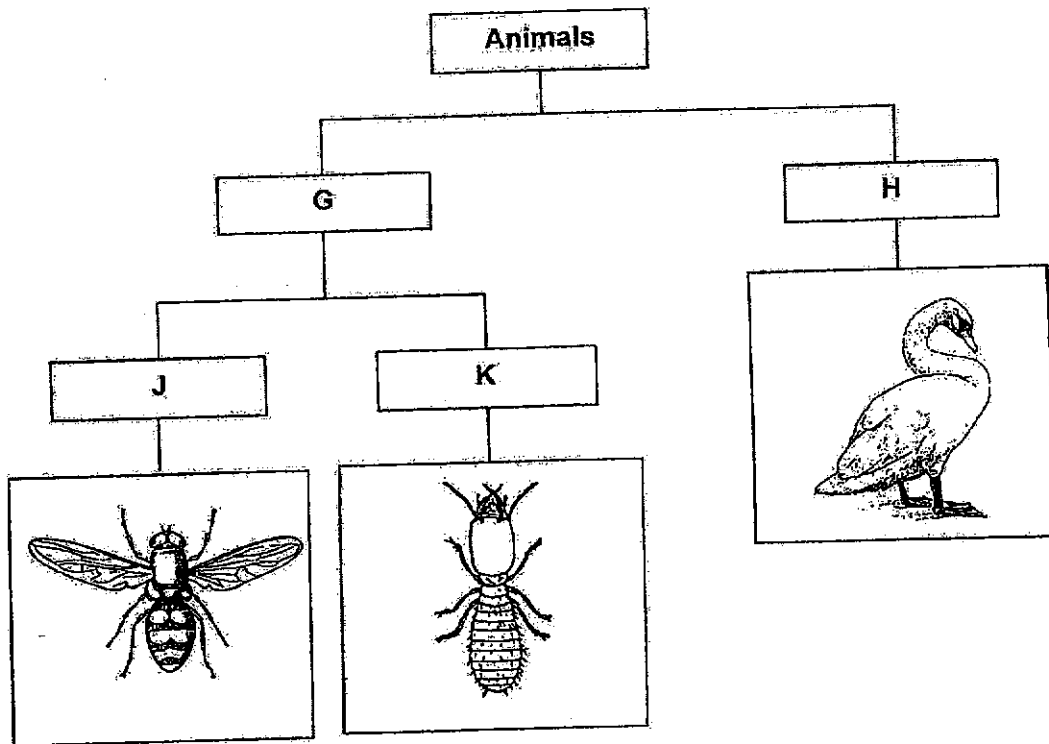

Which of the following are the correct headings for G, H, J and K?

	G	H	J	K
(1)	No feathers	Has feathers	Lays eggs	Does not lay eggs
(2)	Six legs	Two legs	Has wings	No wings
(3)	No beak	Has beak	Does not lay eggs	Lays eggs
(4)	Does not lay eggs	Lays eggs	Has wings	No wings

7. The life cycle of a flowering plant goes through stages X, Y and Z as shown in the diagram below.

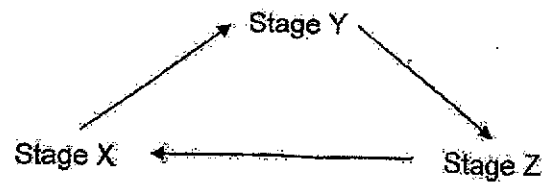

If stage X is the stage of the plant's life cycle where it has no roots yet, what is the name of stage Z of the life cycle?

- (1) egg
 - (2) seed
 - (3) adult plant
 - (4) young plant
8. The diagram below shows the life cycle of an insect.

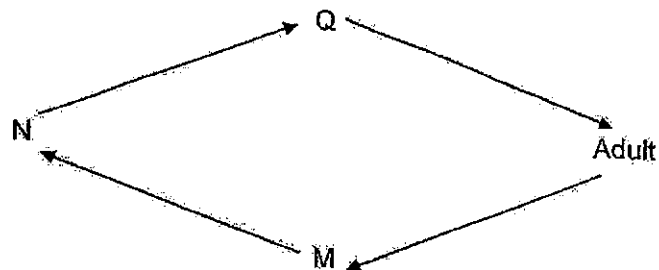

Which of the following shows the correct stages of its life cycle?

	M	N	Q
(1)	Egg	Pupa	Nymph
(2)	Nymph	Pupa	Egg
(3)	Egg	Larva	Pupa
(4)	Pupa	Larva	Egg

9. Which of the animals below has a life cycle that has a different number of stages from the rest?

(1)

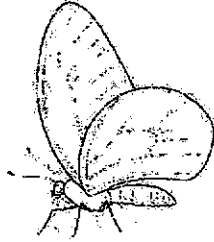

butterfly

(2)

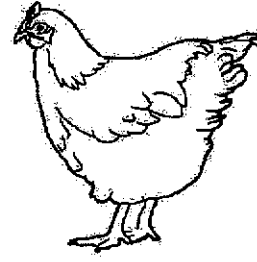

chicken

(3)

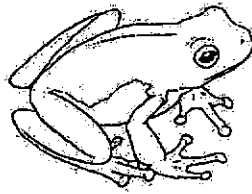

frog

(4)

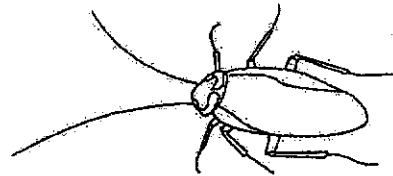

cockroach

10. Study the life cycles of animals, R and S below.

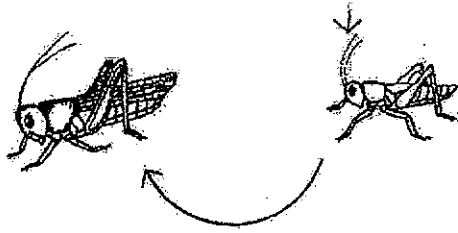

Life cycle of animal R.

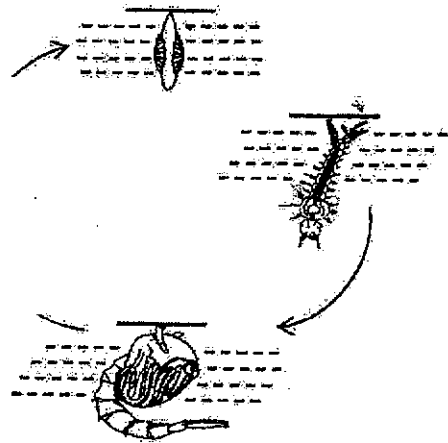

Life cycle of animal S.





Which of the following is true of the life cycles shown above?

- (1) The young of animals, R and S, do not feed.
- (2) The young of animals, R and S, live in water.
- (3) Animal S has a pupal stage while animal R does not have a pupal stage.
- (4) The young of animal R does not look like the adult but the young of animal S does.

11. Abdul observed two animals, T and U, and completed the table as shown below. A tick (✓) means the animal has the characteristic.

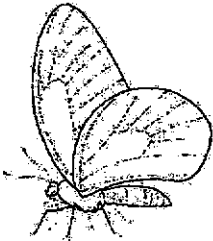
Observation	Animal T	Animal U
It has three body parts.		✓
Its young lives in water.	✓	
Its young looks like its adult.		✓

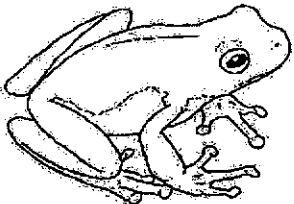
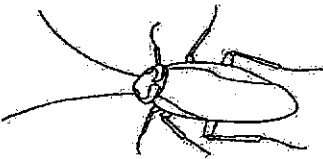
Based on the table above, which of the following animals would most likely represent animals, T and U?

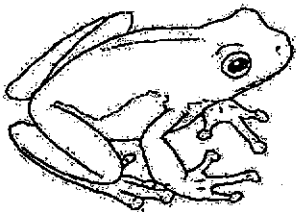
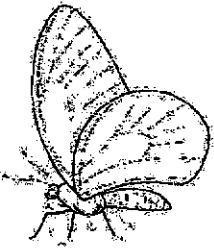
	Animal T	Animal U
(1)		
(2)		
(3)		
(4)		

12. The fireman wears the clothing as shown below when he puts out fires.



Based on the properties shown below, which material, A, B, C or D, is the most suitable for making the fireman's clothing?

	Material	Property		
		flexible	waterproof	strong
(1)	A	x	x	x
(2)	B	x	✓	✓
(3)	C	✓	✓	✓
(4)	D	✓	x	✓

Key	
✓	: yes
x	: no

13. Study the flowchart below.

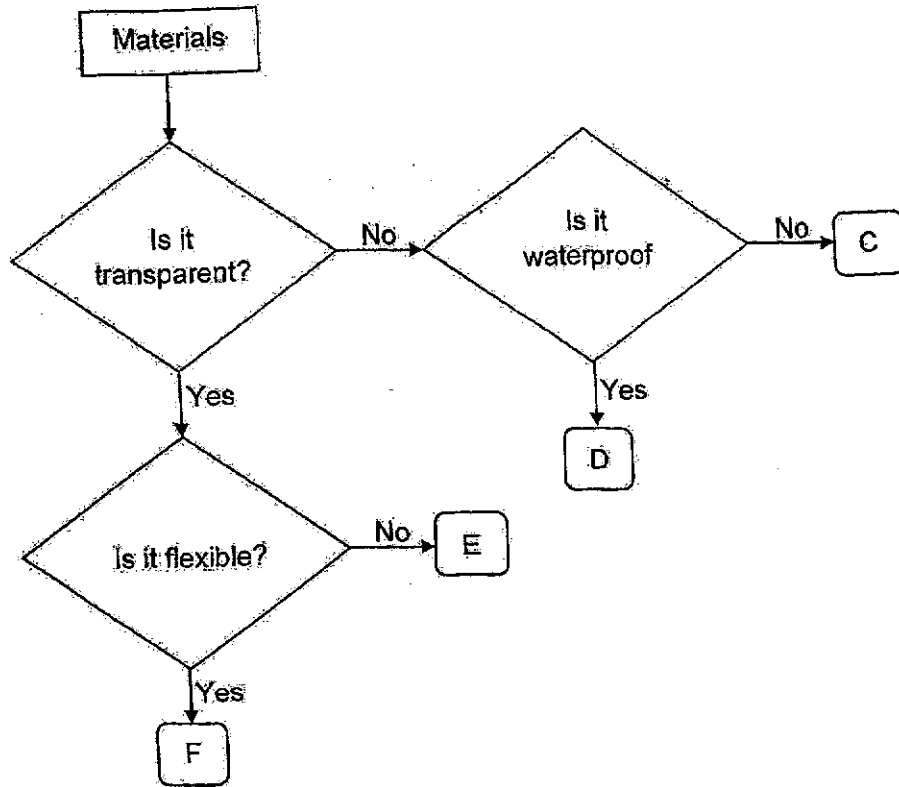

Based on the flowchart above, which of the following materials, C, D, E or F, is used to make the glass panel and metal door handle?

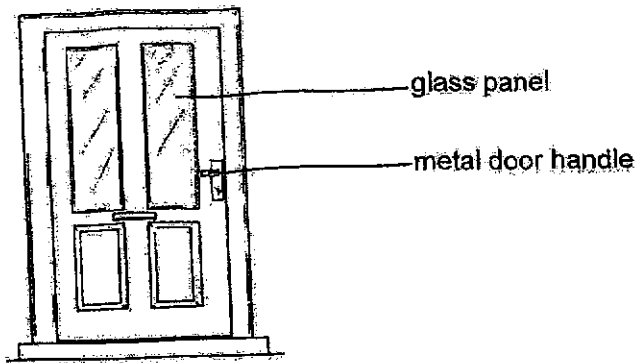

	glass panel	metal door handle
(1)	E	D
(2)	F	E
(3)	D	C
(4)	C	F

14. Study the U-shaped magnet shown below.

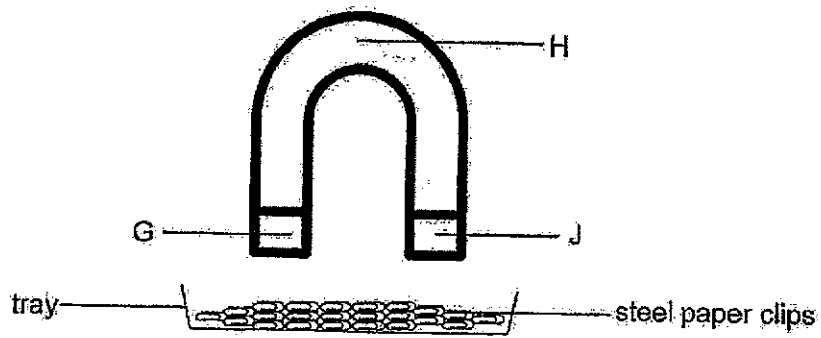

The magnet was placed in a tray of steel paper clips. Which of the following best represents the number of steel paper clips attracted to the parts, G, H and J?

	G	H	J
(1)	5	10	5
(2)	10	5	10
(3)	10	10	10
(4)	10	10	5

15. Mrs Chan displayed a poster on the metal cabinet by placing object K on top of the poster.

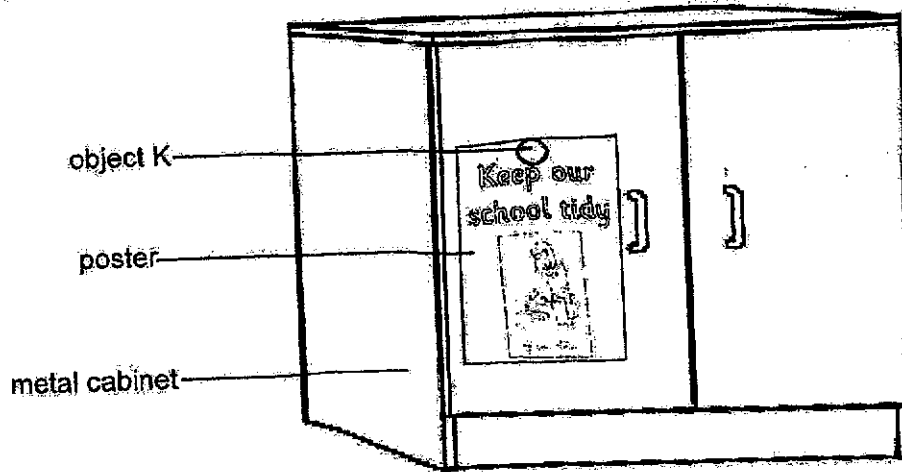

What can object K and the metal cabinet be made of?

	object K	metal cabinet
(1)	magnet	non-magnetic material
(2)	magnetic material	magnetic material
(3)	non-magnetic material	magnet
(4)	magnet	magnetic material

16. Study the set-ups below.

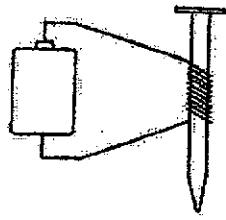

set-up P

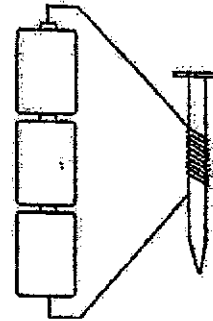

set-up Q

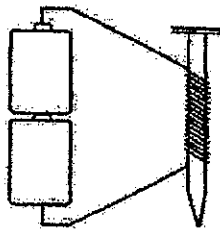

set-up R

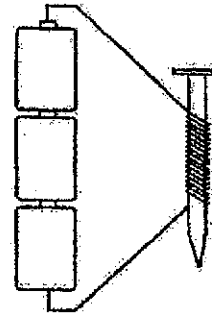

set-up S

Which of the following set-ups, P, Q, R or S, will have the greatest magnetic strength of attraction?

- (1) P
- (2) Q
- (3) R
- (4) S

17. Karen made a chess set as shown below. The chess board has a layer made of Material T. She then folded it as shown and observed if the chess pieces stay on the board.

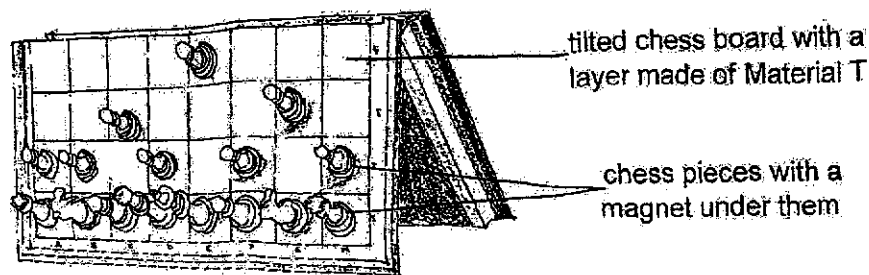

Karen tested the chess pieces again by replacing material T with materials, U, V and W, and recorded her observation in the table shown below.

Material of chess board	Can the chess pieces stay on the board when it is folded?
T	Yes
U	No
V	No
W	Yes

What could Karen infer from this observation?

- (1) Materials T and V are not made of metal.
- (2) Materials U and V are magnetic materials.
- (3) Materials V and W are non-magnetic materials.
- (4) Materials T and W can be attracted to a magnet.

End of Booklet A



PRIMARY 3 PRACTICE PAPER (2024)

Name : _____ ()

Date: _____

Class : Primary 3 ()

Parent's Signature : _____

SCIENCE

BOOKLET B

INSTRUCTIONS TO CANDIDATES

1. Write your name, class and register number.
2. Do not turn over this page until you are told to do so.
3. Follow all instructions carefully.
4. Answer all questions.
5. Write your answers in the booklet.

Booklet A	34
Booklet B	26
Total	60

Booklet B (26 marks)

For questions 18 to 26, write your answers clearly in this booklet.

The number of marks available is shown in brackets [] at the end of each question or part question. (26 marks)

18. The diagram below shows plant A in the wild.

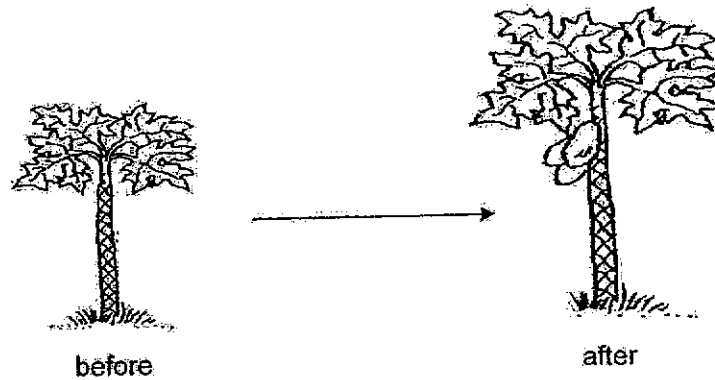

(a) Which characteristic of living things does plant A show? [1]

(b) The diagram below shows the cross-section of the fruit of plant A. How are the seeds important to plant A? [1]

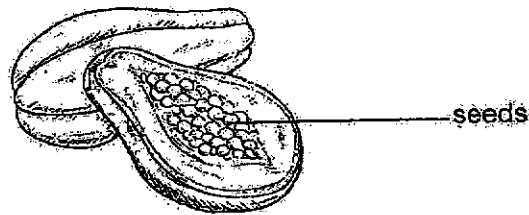

(c) It did not rain for months. What would happen to plant A? Explain why. [1]

Score	3
-------	---

19. Sarah drew pictures of different stages of the life cycle of a plant. B, C and D are the different stages of the life cycle.

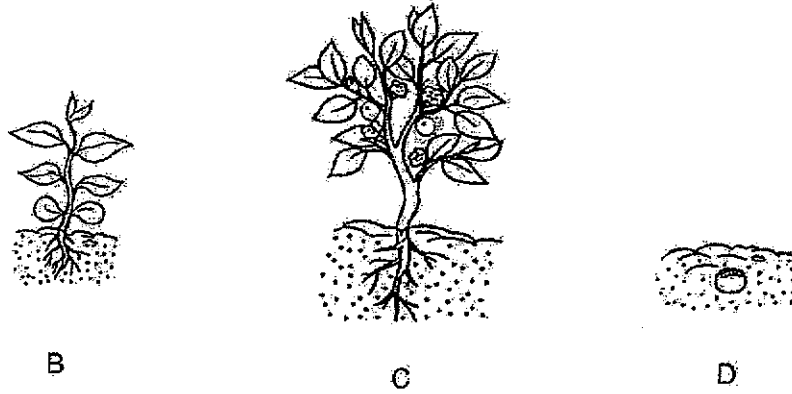

(a) Using letters B, C and D, fill in the boxes to complete the life cycle of the plant. [1]

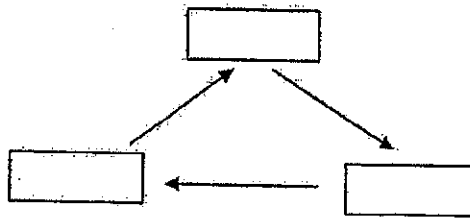

(b) State one difference of a plant part that is shown in both stages B and C. [1]

(c) Based on the pictures shown above, can you conclude this is a flowering plant? Explain why. [1]

Score	3
-------	---

20. Study the flowchart below.

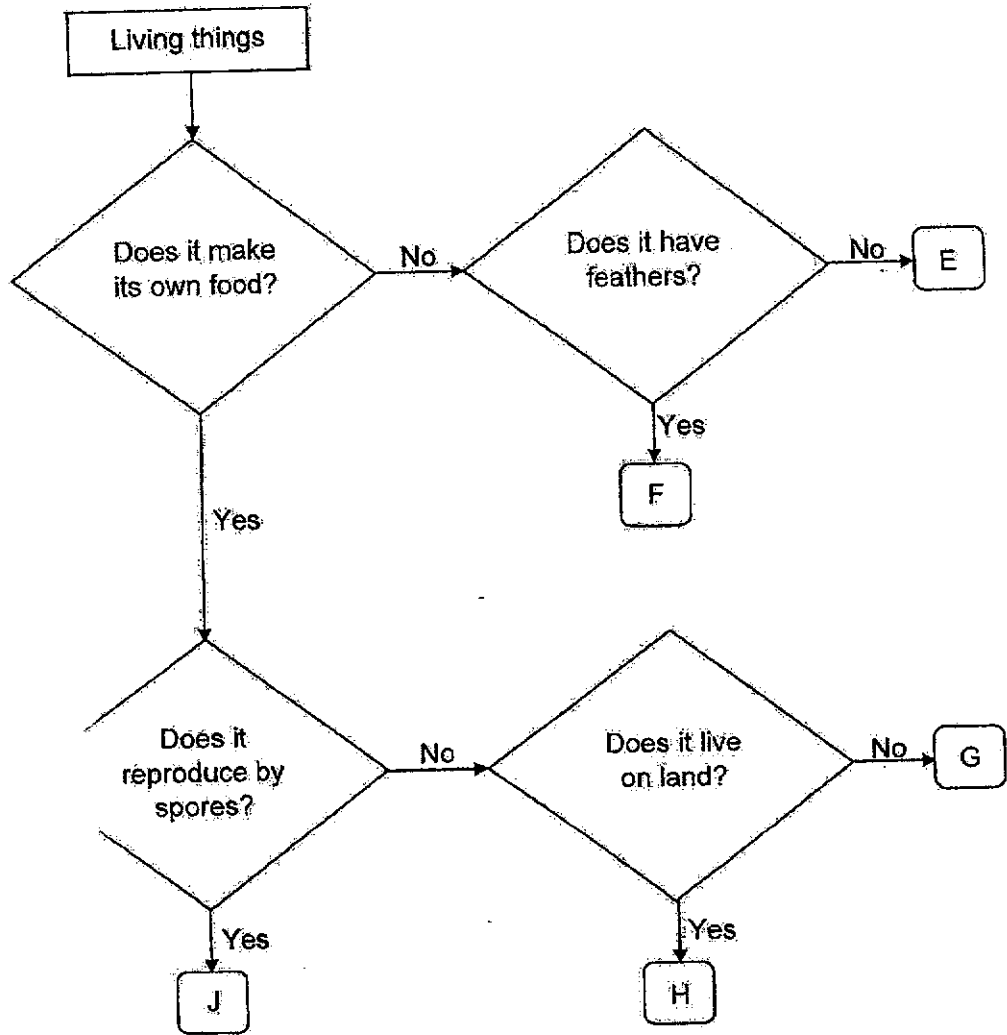

(a) Based on the flowchart, state the difference between living things, H and J. [1]

Score	1
-------	---

(b) Based on the flowchart, write the letters; E, F, G, H or J, that represent the living things shown in the pictures below. [1]

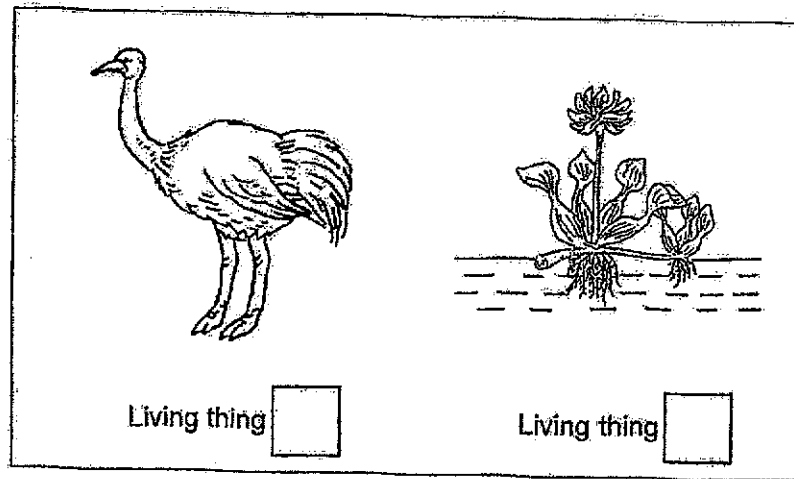

The diagram below shows plant K.

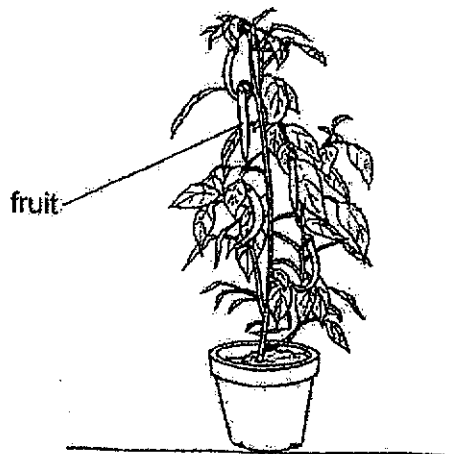

(c) Based on the flowchart, can 'G' be plant K? Explain why. [1]

Score	2
-------	---

21. Kumar conducted an experiment on mealworm beetles. He recorded the amount of food eaten in each stage of its life cycle in the graph below. R, S, egg and adult are the different stages in its life cycle.

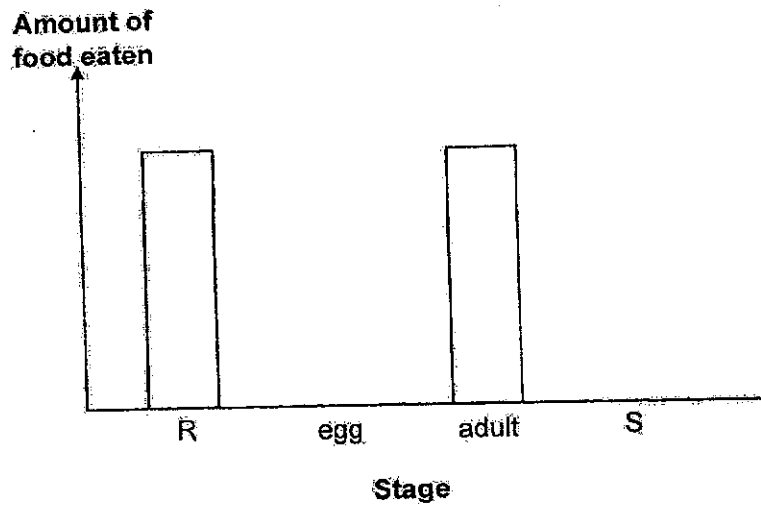

- (a) Based on the information from the graph, at which stage, R or S, is the mealworm beetle a larva? Explain why. [1]

- (b) Based on the graph above, fill in the boxes below with the letters, R or S, to complete the life cycle of the mealworm beetle. [1]

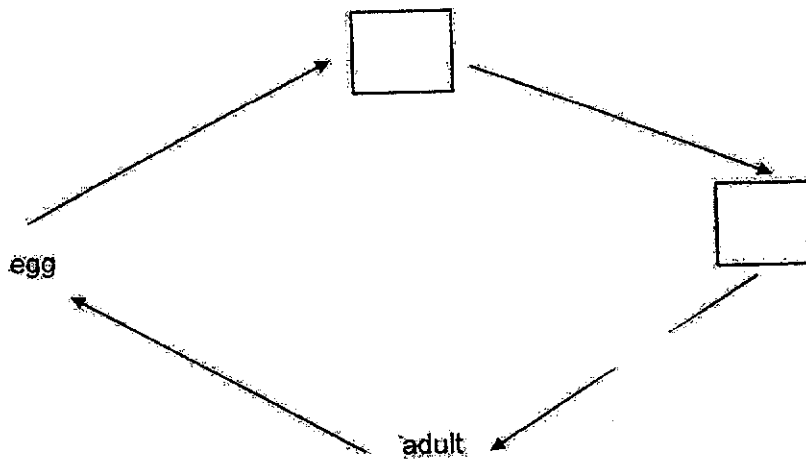

Score	2
-------	---

Mealworm beetles are pests as they feed on plants. The diagrams below show a mealworm beetle and its larva.

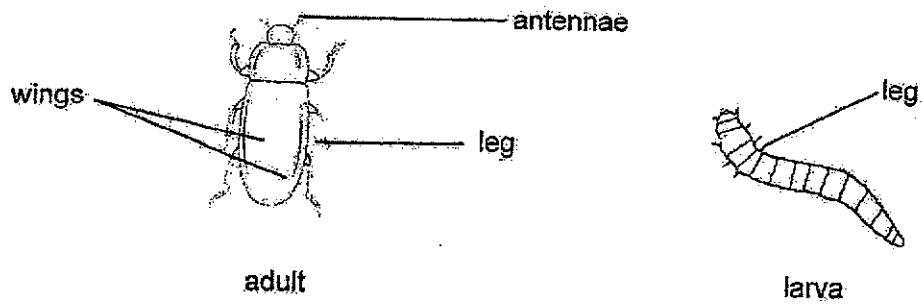

(c) Using a characteristic from the diagrams above, explain why it is more difficult to get rid of the adult than the larva? [1]

Score	1
-------	---

22. Alvin placed three different materials, P, U and V, into three identical containers containing 500 ml of water each. The materials are of the same shape, size, and thickness, as shown in the diagrams below.

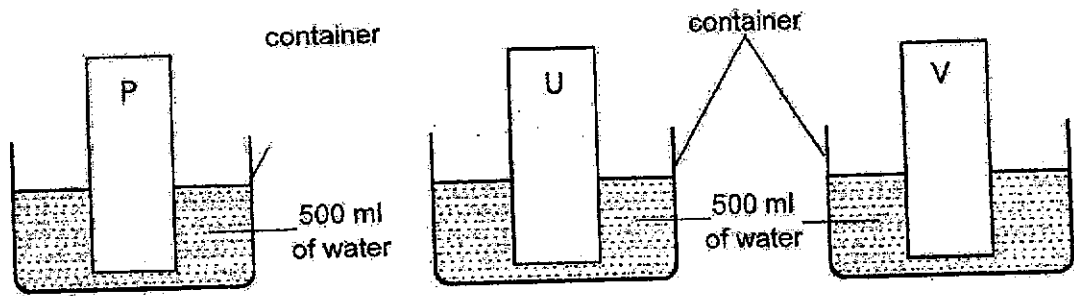

After five minutes, he removed the three materials. The table below shows the amount of water left in the containers.

Material	Amount of water left in the container (ml)
P	200
U	0
V	500

- (a) Arrange the three materials, P, U and V, in order of its ability to absorb water. [1]

--	--	--

does not absorb water at all
→
←
 absorbs the most water

The diagram below shows a beach ball.

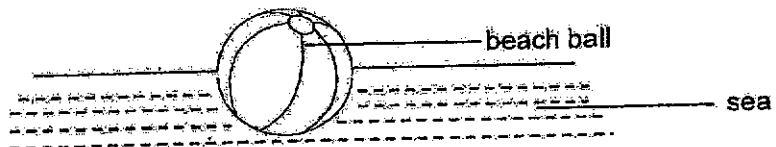

- (b) Apart from being waterproof, what other property must a beach ball have as shown above? [1]

Score	2
-------	---

- *
23. Celine wanted to compare the flexibility of three different materials of same size and length, W, X and Y. She hung a 500 g weight on each sheet of material using an identical string and observed how much the material bent.

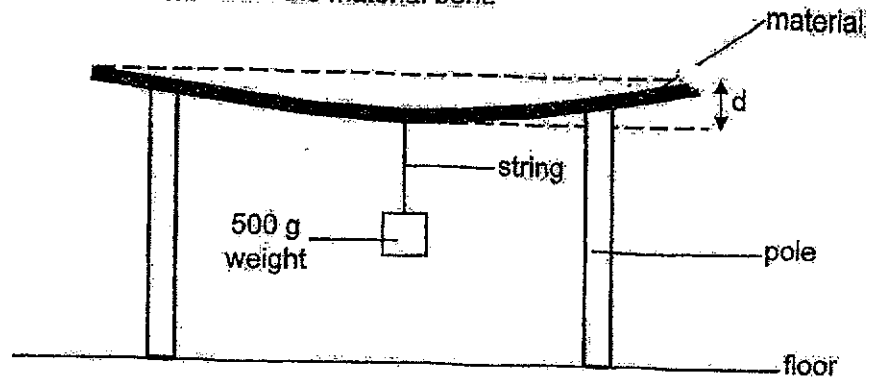

She then measured the distance, d , shown above and recorded the results in the table below.

Material	Distance, d (cm)		
	First Try	Second Try	Third Try
W	1	1	1
X	10	8	12
Y	7	5	6

- (a) Based on Celine's experiment, which material, W, X or Y, is the most flexible? Explain your answer. [1]

The diagram below shows a basket with some books.

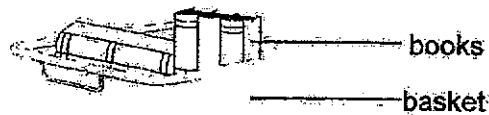

- (b) Based on Celine's experiment, which material, W, X or Y, is the most suitable for making the basket? Explain your answer. [1]

Score	2
-------	---

24. Dan set up an experiment as shown below.

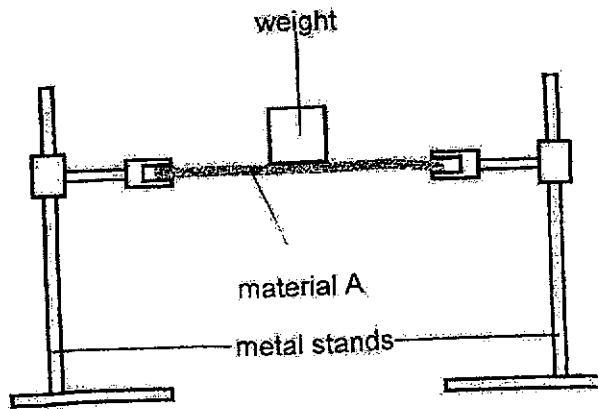

Weights of different mass were placed on material A until the material broke. The experiment was then repeated with different materials, B and C. The results were shown in the table below.

Material	Mass needed for the material to break (kg)
A	10
B	35
C	50

- (a) What property of material was Dan trying to test?

[1]

- (b) Tick (✓) the variable(s) that must be kept the same to make the experiment a fair test.

[1]

Variable	Variable(s) that must be kept the same
type of material	
length of material	
thickness of material	

Score	2
-------	---

Dan wants to make a hammock using material B so that he can sleep on it as shown below.



hammock made of
material B

- (c) Dan's mass is 37 kg. Would it be safe for him to sleep on the hammock? Explain why. [2]

Score	2
-------	---

25. Siti makes four magnets, K, L, M and N, using the stroking method.

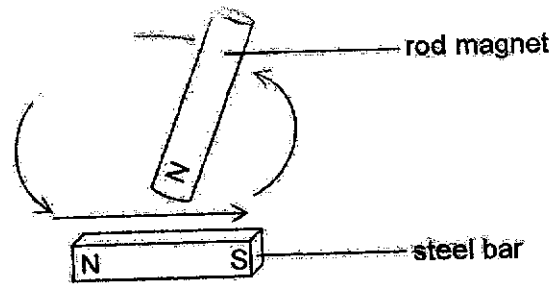

She used these magnets to attract some iron pins as shown below.

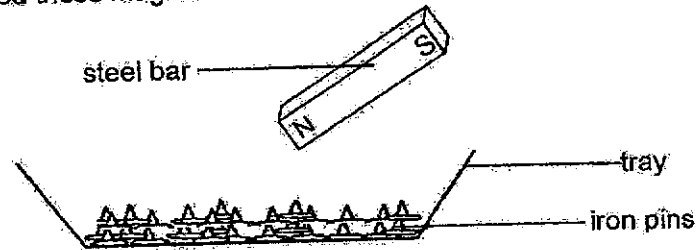

She recorded her observations in the table below.

Bars	Number of strokes	Number of iron pins attracted
K	20	2
L	30	6
M	40	Y
N	50	14

- (a) Based on the results above, what is the likely value of Y? [1]

- (b) What can Siti conclude about the relationship between the number of strokes and the magnetic strength of the steel bar? [1]

Score	2
-------	---

Siti attached the steel bar K on the duster as shown below. When the duster was placed on the whiteboard, it kept sliding down.

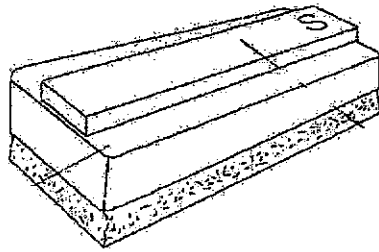

steel bar K

back of the duster

(c) Which bar, L, M or N, should she replace so that the duster will least likely slide down the whiteboard? Explain why [1]

Score	1
-------	---

26. The diagram below shows a toy train E being pulled towards magnet X quickly after it is released a distance away from magnet X.

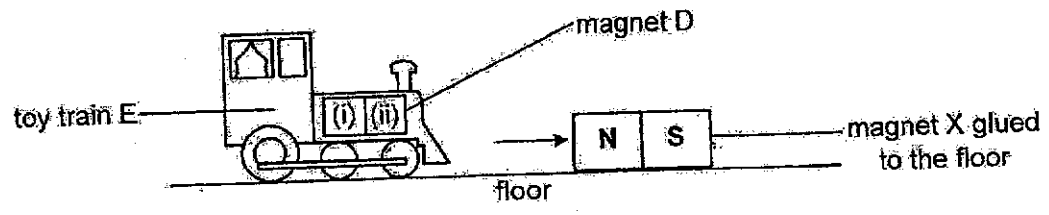

(a) Fill in the blanks, (i) and (ii), with 'N' and 'S' to represent the poles of magnet D. [1]

(i) : _____ (ii) : _____

(b) Explain why toy train E is pulled towards magnet X. [1]

Kim Yong brought toy train E close to toy train F as shown below. Toy train F did not move at all.

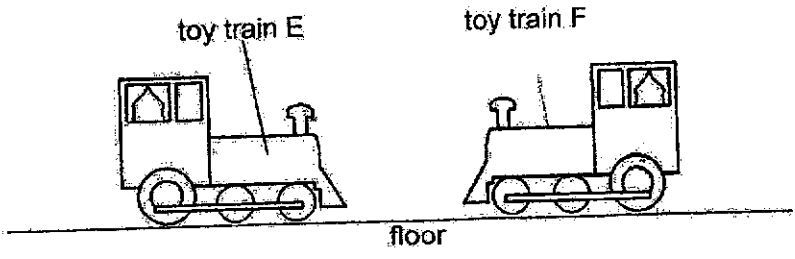

(c) Explain why toy train F did not move at all. [1]

Score	3
-------	---

End of Booklet B

SCHOOL : TAO NAN PRIMARY SCHOOL
 LEVEL : PRIMARY 3
 SUBJECT : SCIENCE
 TERM : PRACTICE PAPER

BOOKLET A

Q1	Q2	Q3	Q4	Q5	Q6	Q7	Q8	Q9
4	4	4	3	1	2	3	3	1
Q10	Q11	Q12	Q13	Q14	Q15	Q16	Q17	
3	2	3	1	2	4	4	4	

BOOKLET B

Q18(a)	Living things can grow.
Q18(b)	The seeds help plant A to reproduce.
Q18(c)	Plant A would die. Living things require water to survive, without rain plant A would not have water hence it will die.
Q19(a)	
Q19(b)	Stage C has flowers but stage B does not have flowers.
Q19(c)	Yes. The plant produces flowers in the adult stage.
Q20(a)	J reproduces by spores but H does not.
Q20(b)	Living thing F, Living thing G
Q20(c)	No. G does not live on land but plant K lives on land.

Q21(a)	Stage R. The larva stage feeds during that stage, so it is stage R as S does not show any feeding.								
Q21(b)	<pre> graph TD egg --> R R --> S S --> adult adult --> egg </pre>								
Q21(c)	The adult has wings to fly but the larva does not.								
Q22(a)	V - P - U								
Q22 (b)	It must float on water								
Q24(a)	Strength of the material.								
Q24(b)	<table border="1"> <thead> <tr> <th>Variable</th> <th>Variable(s) that must be kept the same</th> </tr> </thead> <tbody> <tr> <td>type of material</td> <td></td> </tr> <tr> <td>length of material</td> <td>✓</td> </tr> <tr> <td>thickness of material</td> <td>✓</td> </tr> </tbody> </table>	Variable	Variable(s) that must be kept the same	type of material		length of material	✓	thickness of material	✓
Variable	Variable(s) that must be kept the same								
type of material									
length of material	✓								
thickness of material	✓								
Q24(c)	No. Material B can only hold 35 kg but Danis is 37 kg, he is heavier than the hammock. Hence, the hammock will break and he will fall and get injured.								
Q25(a)	10.								
Q25(b)	As the number of strokes increases, the magnetic strength of the steel bar increases.								
Q25(c)	Bar N. It attracted the most number of iron pins, hence it has the strongest magnetic strength and it will not slide down the whiteboard.								
Q26(a)	(i) N (ii) S								

Q26(b)	The south pole of magnet D and the north pole of magnet X are facing each other, hence they attract.
Q26(c)	Train F is made of a non-magnetic material, hence they cannot attract or repel train E.

23)a)X. X bent the most when hanging the same amount of weight.

b)W. W is the stiffest as it bent the same distance in every try so the basketry will be able to carry the books.

